



Messrs.				
Product Specification	Model: <i>AWG-S32240AMBHSGWH-F</i>	Rev. No.	Issued Date.	Page.
		A	2008/10/06	1 / 21

LIQUID CRYSTAL DISPLAY MODULE
MODEL: A WG-S32240AMBHSGWH-F
Customer's No.:

Acceptance

9 -1 Floor, No.192, Tahtung Road,
 Sec. 3, Hsi-Chih City,
 Taipei Hsien, Taiwan

Approved and Checked by

Approved by	Checked by		Made by
 樺 叡 2008/10/06 NICK	 樺 叡 2008/10/06 JOE		 樺 叡 2008/10/06 TOM

Messrs.					
Product Specification	Model:	AWG-S32240AMBHSGWH-F	Rev. No.	Issued Date.	Page.
			A	2008/10/06	3 / 21

CONTENTS

1.	General Specifications	4
2.	Electrical Specifications	5
2.1	Absolute Maximum Ratings	5
2.2	DC Characteristics	5
2.3	AC Characteristics	6
2.4	Power Supply ON/OFF Sequence	7
2.5	Spec. for LED back-light	8
3.	Optical Specifications	9
3.1	LCD Driving Voltage Recommended	9
3.2	Optical Characteristics	10
3.3	Definition of Viewing Angle	10
3.4	Definition of Viewing Angle θ_F and θ_B	11
3.5	Definition of Contrast Ratio(Cr)	11
4.	I/O Terminal	11
4.1	Pin Assignment	12
4.2	Example of Power Supply	13
4.3	Block Diagram	14
5.	Reliability Test	15
5.1	Test Item	15
5.2	Judgment Standard	16
6.	Appearance Standards	17
6.1	Inspection Conditions	17
6.2	Definition of Applicable Zones	17
6.3	Standards	17
7.	Handling and Precautions	19
8.	Warranty:	20
9.	Dimensional Outlines	21

Messrs.					
Product Specification	Model:	AWG-S32240AMBHSGWH-F	Rev. No.	Issued Date.	Page.
			A	2008/10/06	4 / 21

1. General Specifications

Operating Temperature	:	Min. -20°C ~ Max. 70°C
Storage Temperature	:	Min. -30°C ~ Max. 80°C
Dot Pixels	:	320 (W) x 240 (H) dots
Dot Size	:	0.33 (W) x 0.33 (H) mm
Dot Space	:	0.03 (W) x 0.03 (H) mm
Viewing Area	:	122.0 (W) x 92.0 (H) mm
Display Area	:	115.15(W)x 86.39(H) mm
Viewing Area	:	122.0 (W) x 92.0 (H) mm
Outline Dimensions	:	167.1* (W) x 109.0** (H) x 12.4.0 max.*** (D) mm
		* Without FFC Cable
		** Without LED Cable
Weight	:	N/A
LCD Type	:	STN/ Negative, Blue mode/ Transmissive
Viewing Direction	:	6 O'clock
Data Transfer	:	8-bit parallel data transfer
Controller LSI	:	RA8835
T/P Controller	:	ADS7843
DC-DC	:	AIC 1652
Backlight	:	With LED B/L
Drawings	:	As attached drawings

Messrs.					
Product Specification	Model:	AWG-S32240AMBHSGWH-F	Rev. No.	Issued Date.	Page.
			A	2008/10/06	5 / 21

2. Electrical Specifications

2.1 Absolute Maximum Ratings

$V_{SS} = 0V$

Parameter	Symbol	Conditions	Min.	Max.	Units
Supply Voltage (Logic)	$V_{DD} - V_{SS}$	--	- 0.3	7.0	V
Supply Voltage (LCD Drive)	$V_{LCD} - V_{SS}$	--	0	35.0	V
Input Voltage	V_I	--	- 0.3	$V_{DD} + 0.3$	V

2.2 DC Characteristics

$T_a = 25^\circ C, V_{SS} = 0V$

Parameter	Symbol	Conditions	Min.	Typ.	Max.	Units
Supply Voltage (Logic)	$V_{DD} - V_{SS}$	--	4.5	5.0	5.5	V
Supply Voltage (LCD Drive)	$V_{DD} - V_{EE}$	--	12.0	--	32.0	V
	$V_{DD} - V_O$	Shown in 3.1				V
High Level (Input Voltage)	V_{IH}	--	$0.8 \times V_{DD}$	--	V_{DD}	V
Low Level (Input Voltage)	V_{IL}	--	V_{SS}	--	$0.2 \times V_{DD}$	V
High Level (Output Voltage)	V_{OH}	$I_{OH} = -0.5mA$	2.4	--	--	V
Supply Current	I_{DD}	$V_{DD} = 5.0V$	--	50	80	mA
	I_{EE}	$V_{DD} = 5.0V$	--	3.0	5.0	mA
Frame	f_F	Duty = 50%	32	64	128	Hz

Messrs.				
Product Specification	Model: <i>AWG-S32240AMBHSGWH-F</i>	Rev. No.	Issued Date.	Page.
		A	2008/10/06	6 / 21

2.3 AC Characteristics

2.3.1 8080 family interface timing

Ta=-20 to 75°C

Signal	Symbol	Parameter	V _{DD} = 4.5 to 5.5		V _{DD} = 2.7 to 4.5		Units	Condition
			Min.	Max.	Min.	Max.		
A0, CS	t _{AH8}	Address hold time	10	--	10	--	ns	CL=100pF
	t _{AW8}	Address setup time	0	--	0	--	ns	
WR, RD	t _{CYC8}	System cycle time	See note	--	See note	--	ns	
	t _{CC}	Strobe pulse width	120	--	150	--	ns	
DB0 to DB7	t _{DS8}	Data setup time	120	--	120	--	ns	
	t _{DH8}	Data hold time	5	--	5	--	ns	
	t _{ACC8}	RD access time	--	50	--	80	ns	
	t _{OH8}	Output disable time	10	50	10	55	ns	

Note: For memory control and system control commands:

$$t_{CYC8} = 2t_c + t_{CC} + t_{CEA} + 75 > t_{ACV} + 245$$

For all other commands:

$$t_{CYC8} = 2t_c + t_{CC} + 30$$

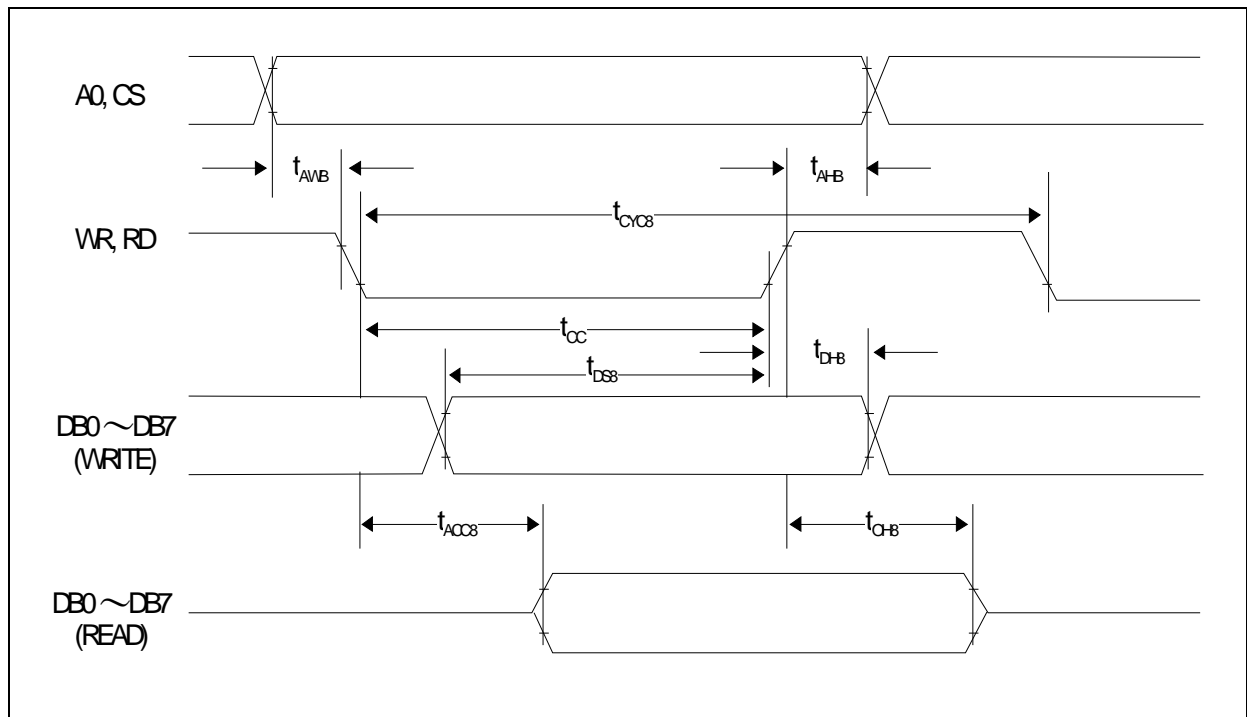

2.3.2 6800 family interface timing

ACROWISE 樺叡電子股份有限公司

台北縣汐止市大同路三段 192 號 9 樓之一, TEL:(02)8647-2888, FAX(02)8647-2999

Messrs.				
Product Specification	Model: <i>AWG-S32240AMBHSGWH-F</i>	Rev. No.	Issued Date.	Page.
		A	2008/10/06	7 / 21

Ta=-20 to 75°C

Signal	Symbol	Parameter	V _{DD} = 4.5 to 5.5		V _{DD} = 2.7 to 4.5		Units	Condition
			Min.	Max.	Min.	Max.		
A0, CS, R/W	t _{CYC6}	System cycle time	See note	--	See note	--	ns	CL=100pF
	t _{AW6}	Address setup time	0	--	10	--	ns	
	t _{AH6}	Address hold time	0	--	0	--	ns	
DB0 to DB7	t _{DS6}	Data setup time	100	--	120	--	ns	
	t _{DH6}	Data hold time	0	--	0	--	ns	
	t _{OH6}	Output disable time	10	50	10	75	ns	
	t _{ACC6}	Access time	--	85	--	130	ns	
WR, RD	t _{EW}	Enable pulse width	120	--	150	--	ns	

Note: For memory control and system control commands:

$$t_{CYC6} = 2t_C + t_{EW} + t_{CEA} + 75 > t_{ACV} + 245$$

For all other commands:

$$t_{CYC6} = 4t_C + t_{EW} + 30$$

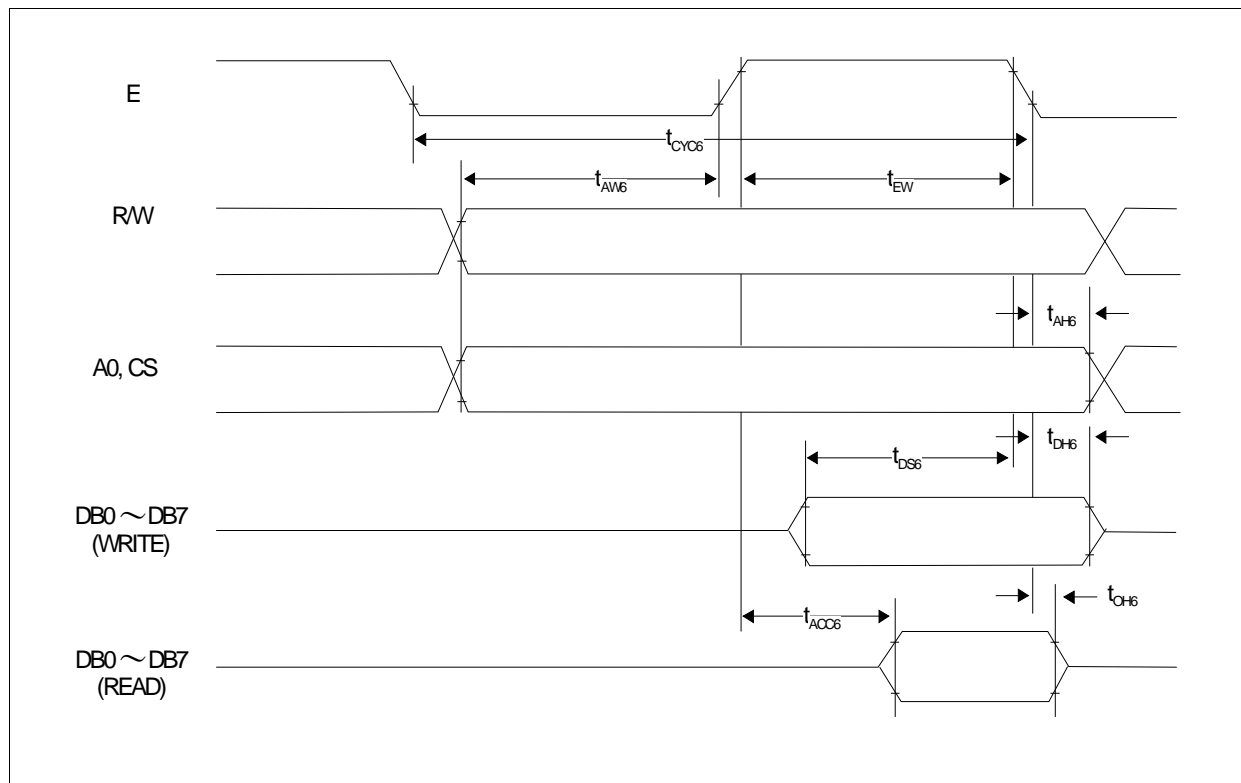

Note: JUMPER SETTING

80 family JUMP J80 Short

68 family JUMP J68 Short

2.4 Power Supply ON/OFF Sequence

2.4.1 ON Sequence

ACROWISE 樺叡電子股份有限公司
台北縣汐止市大同路三段 192 號 9 樓之一, TEL: (02)8647-2888, FAX: (02)8647-2999

Messrs.				
Product Specification	Model: <i>AWG-S32240AMBHSGWH-F</i>	Rev. No.	Issued Date.	Page.
		A	2008/10/06	8 / 21

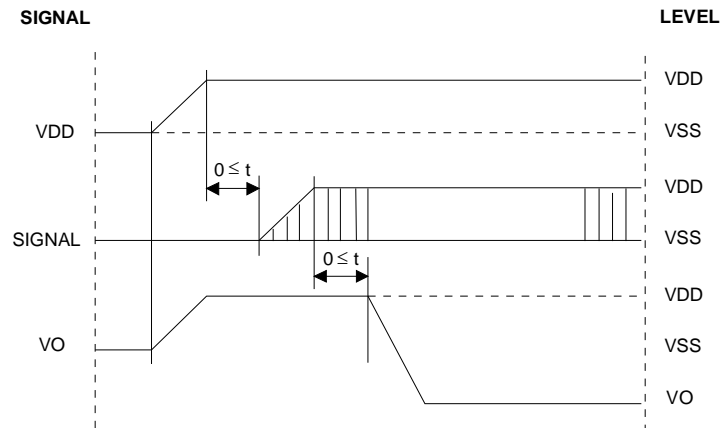

2.4.2 OFF Sequence

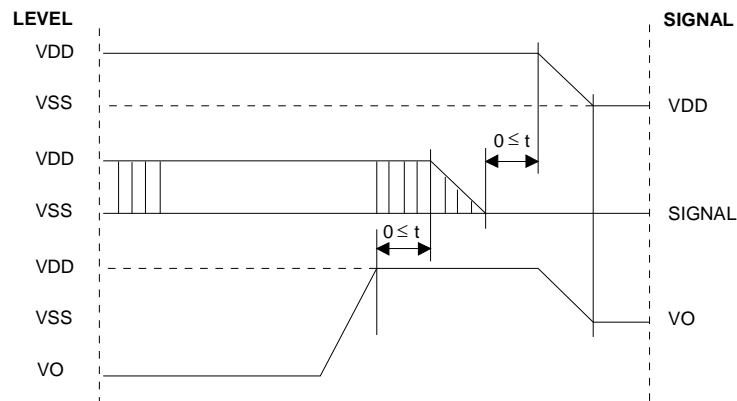

Please maintain the above sequence when turning on and off the power supply of the module. If V_{EE} is supplied to the module while internal alternate signal for LCD driving (M) is unstable or RESET is active, DC component will be supplied to the LCD panel. This may cause damage to the LCD module.

2.5 Spec. for LED back-light

2.5.1 Absolute Maximum Ratings

ACROWISE 樺叡電子股份有限公司
 台北縣汐止市大同路三段 192 號 9 樓之一, TEL:(02)8647-2888, FAX(02)8647-2999

Messrs.				
Product Specification	Model: <i>AWG-S32240AMBHSGWH-F</i>	Rev. No.	Issued Date.	Page.
		A	2008/10/06	9 / 21

Parameter	Symbol	Conditions	Max	Units
Forward Current	I _{AF}	--	180	mA
Reverse Voltage	V _R	--	5.0	V
LED Power Dissipation	P _D	--	0.9	W
Operation Temperature	T _{OPR}		-20 to 70	°C
Storage Temperature	T _{STG}		-40 to 80	°C

2.5.2 Operating Characteristics

T_a = 25°C

Parameter	Symbol	Conditions	Min	Typ.	Max	Units
Forward Current*	I _F	V _F =5V			175	mA
Reverse Current	I _R	V _R =5.0V	--	--	0.3	mA
Luminance of Backlight Surface	L	V _F =5V	400	--	--	cd/m ²
Uniformity**			75	80	--	%
AVG. x of 1931 C.I.E.	X		0.27	0.30	0.33	--
	Y	0.25	0.28	0.31	--	

*Measured between A,K (see the figure below)

**Uniformity = (Min./Max.) x 100%

2.5.3 Schematics Related

Typical Internal Equivalent Circuit

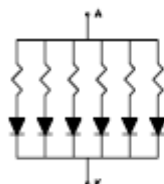

1X6=6 (SMD Numbers)

3. Optical Specifications

3.1 LCD Driving Voltage Recommended

ACROWISE 樺叡電子股份有限公司
台北縣汐止市大同路三段 192 號 9 樓之一, TEL:(02)8647-2888, FAX(02)8647-2999

Messrs.				
Product Specification	Model: <i>AWG-S32240AMBHSGWH-F</i>	Rev. No.	Issued Date.	Page.
		A	2008/10/06	10 / 21

Parameter	Symbol	Conditions	Min.	Typ.	Max.	Units
LCD Driving Voltage (Note 1)	$V_{DD}-V_O$	Ta = -20 °C	24.7	25.2	25.7	V
		Ta = 25 °C	20.8	21.2	21.6	V
		Ta = 70 °C	19.5	20.0	20.5	V

Note 1 : Voltage (Applied actual waveform to LCD panel) for the best contrast. The range of minimum and maximum shows tolerance of the operating voltage. The specified contrast ratio and response time are not guaranteed over the entire range.

3.2 Optical Characteristics

Ta=25 °C, 1/240 Duty, 1/11.5 Bias, $V_{DD} = 5.0V$ (Note 4)

Parameter	Symbol	Conditions	Min.	Typ.	Max.	Units	
Contrast Ratio (Note 1)	CR	Ta=25 °C	4	5.5	8	--	
Viewing Angle (Shown in 3.3)	F-R	θ Ta=25 °C	--	65	--	deg.	
	R-L	ϕ Ta=25 °C	--	-30 +30	--	deg.	
Response Time	Rise (Note 2)	T_{ON}	Ta = 25 °C	100	120	180	msec
	Fall (Note 3)	T_{OFF}	Ta = 25 °C	110	140	210	msec

Note 1 : Contrast ratio is defined as follows.

$$CR = L_{OFF} / L_{ON}$$

L_{ON} : Luminance of the ON segments, L_{OFF} : Luminance of the OFF segments

Note 2 : The time that the luminance level reaches 90% of the saturation level from 0% when ON signal is applied.

Note 3 : The time that the luminance level reaches 10% of the saturation level from 100% when OFF signal is applied.

Note 4 : Definition of Driving Voltage V_D . Assuming that the typical driving waveforms shown below are applied to the LCD Panel at 1/A Duty - 1/B Bias (A : Duty Number, B : Bias Number). Driving voltage V_D is defined as follows: $V_D = (V_{th1} + V_{th2}) / 2$

V_{th1} : The voltage VO-P that should provide 50% of the saturation level in the luminance at the segment which the ON signal is applied to.

V_{th2} : The voltage VO-P that should provide 50% of the saturation level in the luminance at the segment which the OFF signal is applied to.

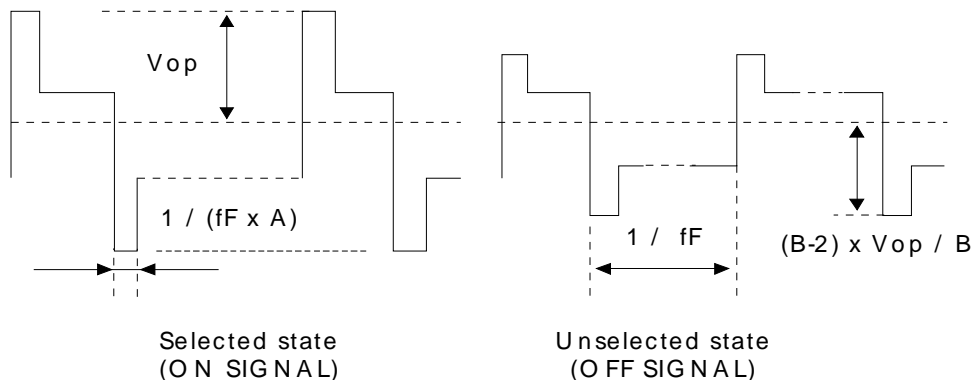

3.3 Definition of Viewing Angle

Messrs.				
Product Specification	Model: <i>AWG-S32240AMBHSGWH-F</i>	Rev. No.	Issued Date.	Page.
		A	2008/10/06	11 / 21

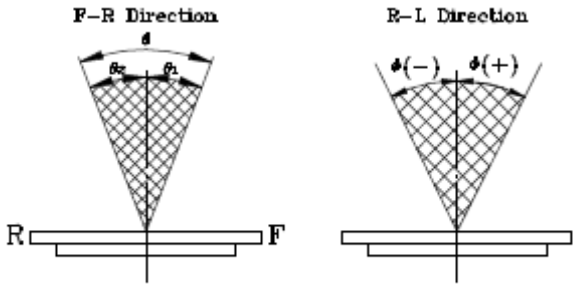

*Conditions
 Operating Voltage : Vop
 Frame Frequency : 70Hz
 Applying Waveform : 1/N duty 1/a bias
 Contrast Ratio : larger than 2
 $\theta = \theta_1 + \theta_2$

3.4 Definition of Viewing Angle θ_F and θ_B

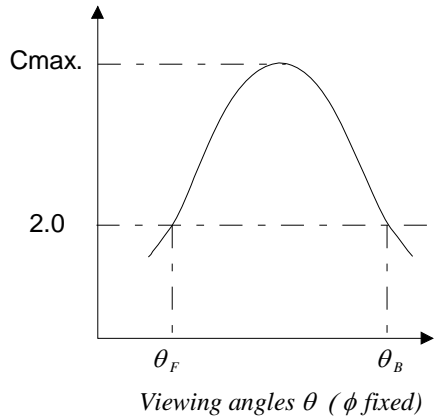

Optimum viewing angle with the naked eye and viewing angle θ at Cmax.
 Above are not always the same.

3.5 Definition of Contrast Ratio(Cr)

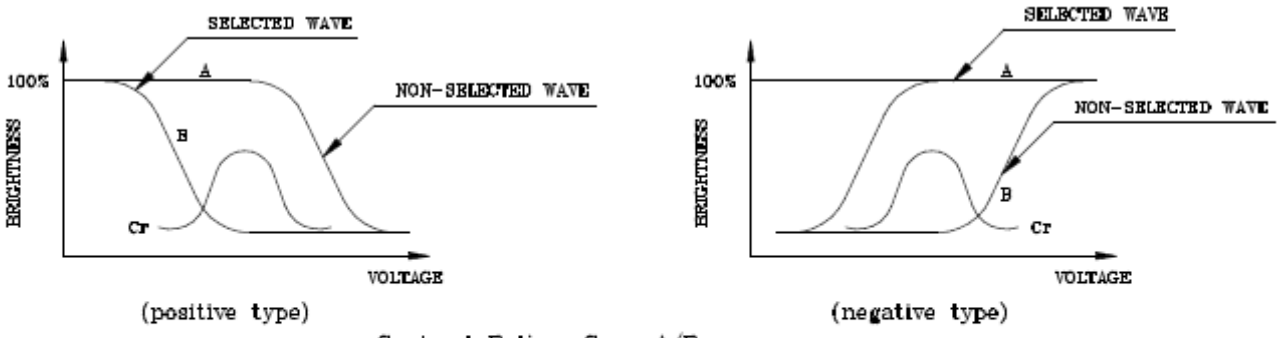

*Conditions
 Operating Voltage : Vop
 Temperature : 25°C
 Viewing Angle (θ, ϕ) : (0,0)
 Frame Frequency : 70Hz
 Applying Waveform : 1/N duty 1/a bias

4. I/O Terminal

Messrs.					
Product Specification	Model:	AWG-S32240AMBHSGWH-F	Rev. No.	Issued Date.	Page.
			A	2008/10/06	12 / 21

4.1 Pin Assignment

CON3

Pin No.	Symbol	Level	Function					
1	V _{SS}	--	Power supply (0V, GND)					
2	V _{DD}	--	Power supply for logic					
3	V _O	--	Voltage level for LCD contrast adjustment					
4	A0	H/L	VRAM address bus					
5	/WR	H/L	VRAM write signal, 8080 family : Write signal 6800 family : R/W signal					
6	/RD	H/L	VRAM read signal, 8080 family : Read signal 6800 family : Enable clock					
7~14	DB0~DB7	H/L	Display data					
15	/CS	H/L	Chip Select, This active-LOW input enables the RA8835. It is usually connected to the output of an address decoder device that maps the RA8835 into the memory space of the controlling microprocessor.					
16	/RST (/RES)	H/L	Reset, This active-LOW input performs hardware reset on the RA8835. It is a Schmitt-trigger input for enhanced noise immunity; however, care should be taken to ensure that it is not triggered if the supply voltage is lowered.					
17	V _{EE}	--	Power Supply for LCD Drive					
18	SEL1	Input	SEL1	Interface	A0	RD	WR	CS
			0	8080 family	A0	RD	WR	CS
			1	6800 family	A0	E	R/W	CS
19	DCLK	--	External Clock Input. This clock runs the SAR conversion process and synchronizes serial data I/O.					
20	CS-T	--	Chip Select input. Controls conversion timing and enables the serial input/output register.					
21	DIN	--	Serial Data Input. If CS is LOW, data is latched on rising edge of DCLK.					
22	DOUT	--	Serial Data Output. Data is shifted on the falling edge of DCLK. This output is high impedance when CS is HIGH.					
23	PEN	--	Pen interrupt					
24	PEN1	--	Pen interrupt setting					
25	IN3	--	Auxiliary Input 1. ADC Input Channel 3.					
26	IN4	--	Auxiliary Input 2. ADC Input Channel 4.					

LED B/L

Pin No.	Symbol	Level	Function
1.	LED A	--	Power supply for LED Backlight (VCC)
2.	NC	--	No-connection
3.	NC	--	No-connection
4.	LED K	--	Power supply for LED Backlight (GND)

ACROWISE 樺叡電子股份有限公司

台北縣汐止市大同路三段 192 號 9 樓之一, TEL:(02)8647-2888, FAX(02)8647-2999

Messrs.					
Product Specification	Model:	AWG-S32240AMBHSGWH-F	Rev. No.	Issued Date.	Page.
			A	2008/10/06	13 / 21

4.2 Example of Power Supply

It is recommended to apply a potentiometer for the contrast adjust due to the tolerance of the driving voltage and its temperature dependence.

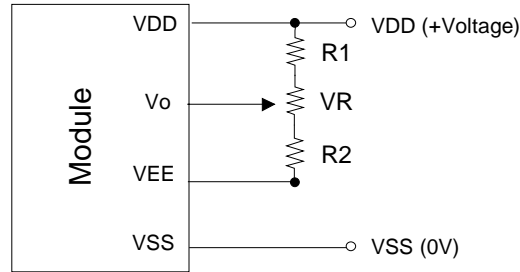

$$R1+R2+VR=10 \sim 20K\Omega$$

Messrs.				
Product Specification	Model: <i>AWG-S32240AMBHSGWH-F</i>	Rev. No.	Issued Date.	Page.
		A	2008/10/06	14 / 21

4.3 Block Diagram

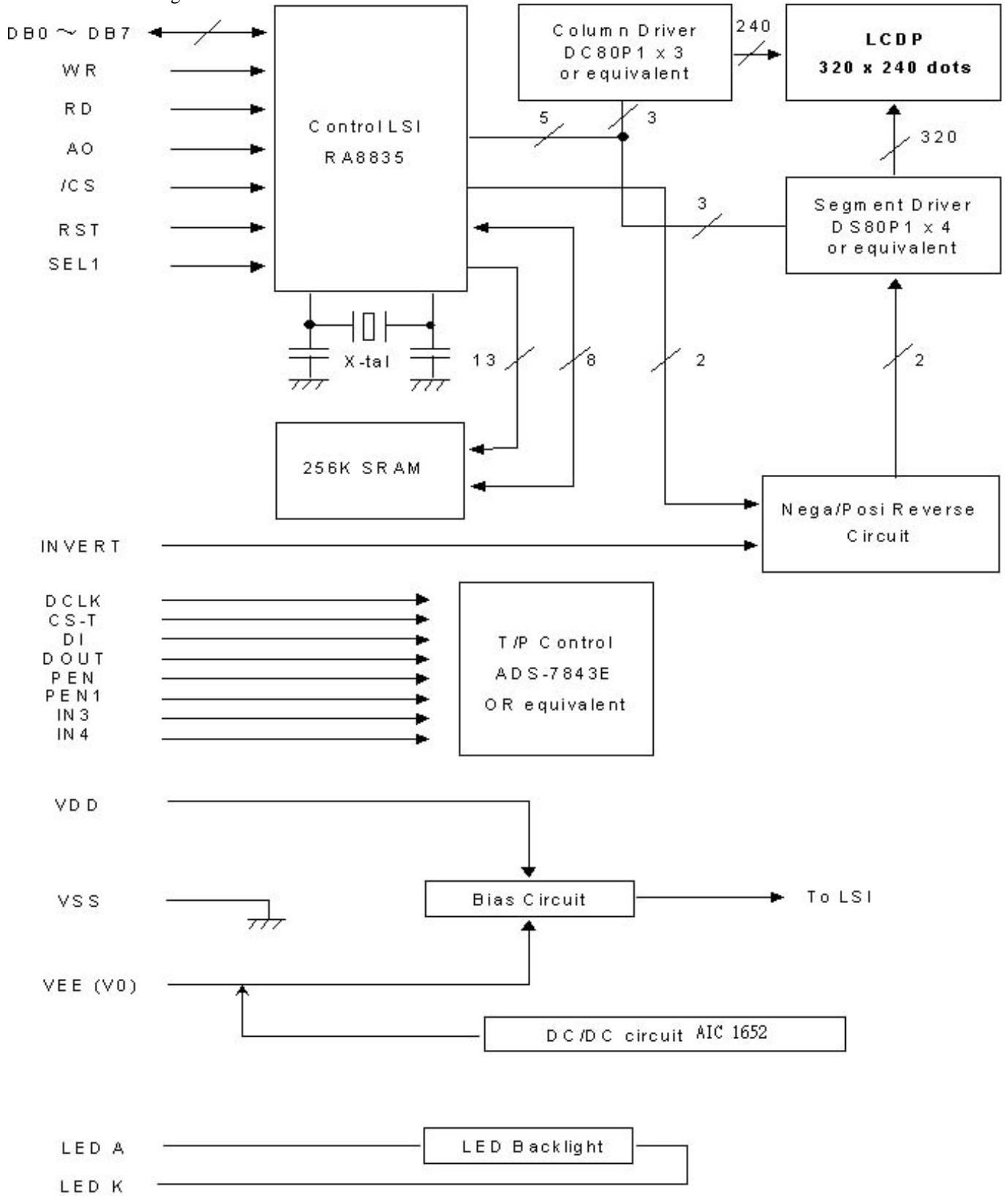

Messrs.				
Product Specification	Model: <i>AWG-S32240AMBHSGWH-F</i>	Rev. No.	Issued Date.	Page.
		A	2008/10/06	15 / 21

5. Reliability Test

5.1 Test Item

No change on display and in operation under the following test condition.

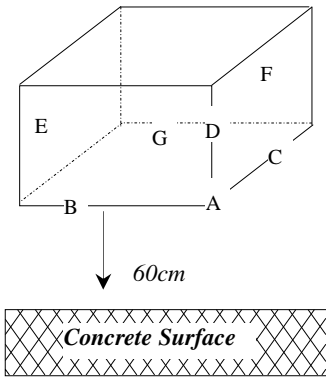
No.	Test Item	Description	Condition	Note
1.	High Temperature (Operation)	Durability test under long time high temperature with electrical stress (voltage, current)	70°C ± 2°C 96hrs	
2.	High Temperature (Storage)	Durability test under long time high temperature storage	80°C ± 2°C 96hrs	4
3.	Low Temperature (Operation)	Durability test under long time low temperature with electrical stress (voltage, current)	-20°C ± 2°C, 96hrs	3
4.	Low Temperature (Storage)	Durability test under long time low temperature storage	-30°C ± 2°C, 96hrs	3, 4
5.	Damp Proof Test	Durability test under long time high temperature and high humidity	40°C ± 2°C, 90~95% RH 96hrs	3, 4
6.	Vibration Test	Total fixed amplitude: 1.5mm Vibration frequency: 10~55Hz One cycle 60 seconds to 3 directions of X, Y, Z for each 15 minutes	--	5
7.	Drop Test	To be measured after dropping from 60cm high on the concrete surface in packing state.  <i>Dropping method corner dropping</i> <i>A corner: once</i> <i>Edge dropping</i> <i>B, C, D edge: once</i> <i>Face dropping</i> <i>E, F, G face: once</i>		

Note 1: Unless otherwise specified, tests will be conducted under the following condition,

Temperature : 25°C ± 2°C

Humidity : 65% ± 5%

Note 2: Unless otherwise specified, tests will be not conducted under functioning state.

Note 3: No dew condensation to be observed.

Note 4: The function test shall be conducted after 4 hours storage at the normal temperature and humidity after removed from the test chamber.

Note 5: Vibration test will be conducted to the product itself without putting it in a container.

Messrs.					
Product Specification	Model:	AWG-S32240AMBHSGWH-F	Rev. No.	Issued Date.	Page.
			A	2008/10/06	16 / 21

5.2 Judgment Standard

Failure Mode	Test Item							Judgment Standard
	1	2	3	4	5	6	7	
Orientation	*	*	*	*	*			No remarkable degradation of appearance under bias/ non-bias condition
Current Value (IAC)	*	*	*	*	*			No remarkable increase
Contrast	*		*	*	*			No remarkable poor contrast
Domain	*	*	*	*	*			Less than 20% of all dots have reverse tilt of more than on third of one dot area.
Bubble (Inside Cell)	*	*	*	*	*	*		As per "Appearance Standard" (Note. Including one which disappear after 25°C 2H)
Polarizer	*				*	*		As per "Appearance Standard" no remarkable appearance change
Glass Damage							*	As per "Appearance Standard"

Note. 1. * is strong linkage between Failure Mode and Test Item.

2. Number of Test Item should be referred to former page.

3. Judgment and Standard value should be fixed by other inspection standard and criteria samples.

Messrs.				
Product Specification	Model: <i>AWG-S32240AMBHSGWH-F</i>	Rev. No.	Issued Date.	Page.
		A	2008/10/06	17 / 21

6. Appearance Standards

6.1 Inspection Conditions

The LCD shall be inspected under 40W white fluorescent light. The distance between the eyes and the sample shall be more than 30cm. All directions for inspecting the sample should be within 45° against perpendicular line.

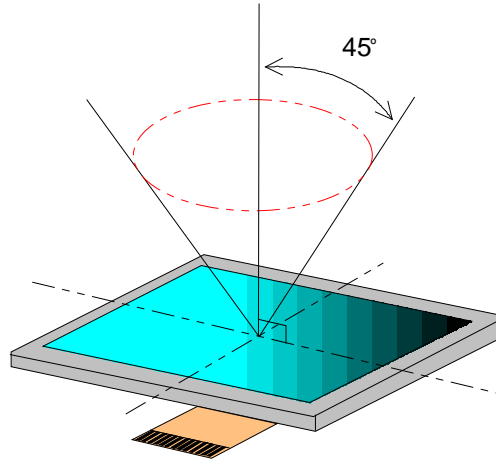

6.2 Definition of Applicable Zones

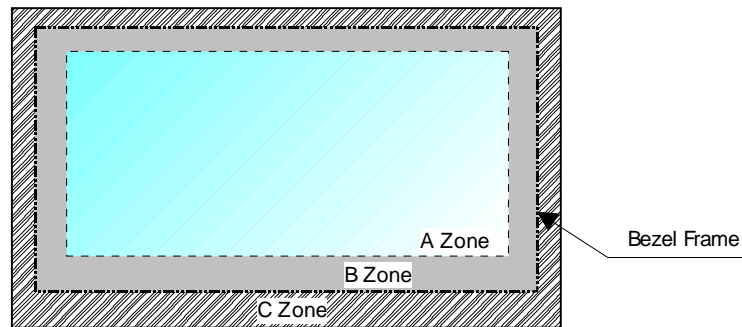

A Zone : Active display area

B Zone : Area from outside of "A Zone" to validity viewing area

C Zone : Rest parts

A Zone + B Zone = Validity viewing area

6.3 Standards

Messrs.					
Product Specification	Model:	AWG-S32240AMBHSGWH-F	Rev. No.	Issued Date.	Page.
			A	2008/10/06	18 / 21

No.	Parameter	Criteria																																																																						
1.	Black and White Spots, Foreign Substances	<p>(1) Round Shape</p> <table border="1"> <thead> <tr> <th rowspan="2">Dimension (mm)</th> <th rowspan="2">Zone</th> <th colspan="3">Acceptable Number</th> </tr> <tr> <th>A</th> <th>B</th> <th>C</th> </tr> </thead> <tbody> <tr> <td>$D \leq 0.2$</td> <td></td> <td>*</td> <td>*</td> <td>*</td> </tr> <tr> <td>$0.2 < D \leq 0.3$</td> <td></td> <td>3</td> <td>5</td> <td>*</td> </tr> <tr> <td>$0.3 < D \leq 0.4$</td> <td></td> <td>2</td> <td>3</td> <td>*</td> </tr> <tr> <td>$0.4 < D \leq 0.5$</td> <td></td> <td>0</td> <td>1</td> <td>*</td> </tr> <tr> <td>$0.5 < D$</td> <td></td> <td>0</td> <td>0</td> <td>*</td> </tr> </tbody> </table> <p>$D = (\text{Long} + \text{Short})/2$ *: Disregard</p> <p>(2) Line Shape</p> <table border="1"> <thead> <tr> <th rowspan="2">X (mm)</th> <th rowspan="2">Y (mm)</th> <th rowspan="2">Zone</th> <th rowspan="2">Zone</th> <th colspan="3">Acceptable Number</th> </tr> <tr> <th>A</th> <th>B</th> <th>C</th> </tr> </thead> <tbody> <tr> <td>--</td> <td>$0.03 \geq W$</td> <td></td> <td></td> <td>*</td> <td>*</td> <td>*</td> </tr> <tr> <td>$2.0 \geq L$</td> <td>$0.05 \geq W$</td> <td></td> <td></td> <td>3</td> <td>3</td> <td>*</td> </tr> <tr> <td>$1.0 \geq L$</td> <td>$0.1 \geq W$</td> <td></td> <td></td> <td>3</td> <td>3</td> <td>*</td> </tr> <tr> <td>--</td> <td>$0.1 < W$</td> <td colspan="4">In the same way (1)</td> </tr> </tbody> </table> <p>X : Length Y: Width *: Disregard</p> <p>Total defects shall not exceed 5.</p>	Dimension (mm)	Zone	Acceptable Number			A	B	C	$D \leq 0.2$		*	*	*	$0.2 < D \leq 0.3$		3	5	*	$0.3 < D \leq 0.4$		2	3	*	$0.4 < D \leq 0.5$		0	1	*	$0.5 < D$		0	0	*	X (mm)	Y (mm)	Zone	Zone	Acceptable Number			A	B	C	--	$0.03 \geq W$			*	*	*	$2.0 \geq L$	$0.05 \geq W$			3	3	*	$1.0 \geq L$	$0.1 \geq W$			3	3	*	--	$0.1 < W$	In the same way (1)			
Dimension (mm)	Zone	Acceptable Number																																																																						
		A	B	C																																																																				
$D \leq 0.2$		*	*	*																																																																				
$0.2 < D \leq 0.3$		3	5	*																																																																				
$0.3 < D \leq 0.4$		2	3	*																																																																				
$0.4 < D \leq 0.5$		0	1	*																																																																				
$0.5 < D$		0	0	*																																																																				
X (mm)	Y (mm)	Zone	Zone	Acceptable Number																																																																				
				A	B	C																																																																		
--	$0.03 \geq W$			*	*	*																																																																		
$2.0 \geq L$	$0.05 \geq W$			3	3	*																																																																		
$1.0 \geq L$	$0.1 \geq W$			3	3	*																																																																		
--	$0.1 < W$	In the same way (1)																																																																						
2.	Air Bubbles (between glass & polarizer)	<table border="1"> <thead> <tr> <th rowspan="2">Dimension (mm)</th> <th rowspan="2">Zone</th> <th colspan="3">Acceptable Number</th> </tr> <tr> <th>A</th> <th>B</th> <th>C</th> </tr> </thead> <tbody> <tr> <td>$D \leq 0.3$</td> <td></td> <td>*</td> <td>*</td> <td>*</td> </tr> <tr> <td>$0.3 < D \leq 0.4$</td> <td></td> <td>3</td> <td>*</td> <td>*</td> </tr> <tr> <td>$0.4 < D \leq 0.6$</td> <td></td> <td>2</td> <td>3</td> <td>*</td> </tr> <tr> <td>$0.6 < D$</td> <td></td> <td>0</td> <td>0</td> <td>*</td> </tr> </tbody> </table> <p>*: Disregard</p> <p>Total defects shall not exceed 3.</p>	Dimension (mm)	Zone	Acceptable Number			A	B	C	$D \leq 0.3$		*	*	*	$0.3 < D \leq 0.4$		3	*	*	$0.4 < D \leq 0.6$		2	3	*	$0.6 < D$		0	0	*																																										
Dimension (mm)	Zone	Acceptable Number																																																																						
		A	B	C																																																																				
$D \leq 0.3$		*	*	*																																																																				
$0.3 < D \leq 0.4$		3	*	*																																																																				
$0.4 < D \leq 0.6$		2	3	*																																																																				
$0.6 < D$		0	0	*																																																																				

To be continued.....

Messrs.				
Product Specification	Model: <i>AWG-S32240AMBHSGWH-F</i>	Rev. No.	Issued Date.	Page.
		A	2008/10/06	19 / 21

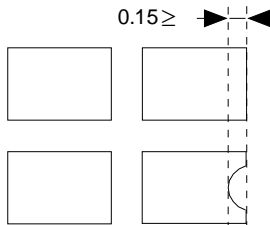
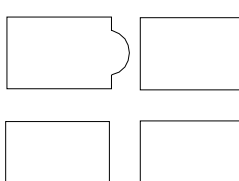
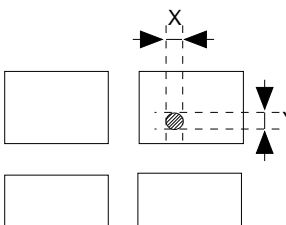
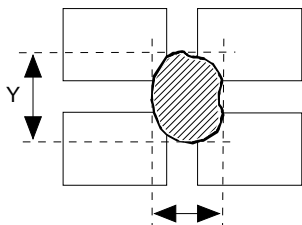
No.	Parameter	Criteria
3.	The Shape of Dot	<p>(1) Dot Shape (with Dent)</p>  <p>0.15 ≥</p> <p>As per the sketch of left hand.</p> <p>(2) Dot Shape (with Projection)</p>  <p>Should not be connected to next dot.</p> <p>(3) Pin Hole</p>  <p>$(X+Y)/2 \leq 0.2\text{mm}$ (Less than 0.1mm is no counted.)</p> <p>(4) Deformation</p>  <p>$(X+Y)/2 \leq 0.2\text{mm}$</p> <p>Total acceptable number: 1/dot, 5/cell (Defect number of (4): 1pc.)</p>
4.	Polarizer Scratches	Not to be conspicuous defects.
5.	Polarizer Dirts	If the stains are removed easily from LCDP surface, the module is not defective.
6.	Complex Foreign Substance Defects	Black spots, line shaped foreign substance or air bubbles between glass & polarizer should be 5pcs maximum in total.
7.	Distance between different Foreign Substance defects	$D \leq 0.2$: 20mm or more $0.2 < D$: 40mm or more

7. Handling and Precautions

Messrs.					
Product Specification	Model:	AWG-S32240AMBHSGWH-F	Rev. No.	Issued Date.	Page.
			A	2008/10/06	20 / 21

The Following precautions will guide you in handling our product correctly.

- 1 Liquid crystal display devices
 - 1.1 The liquid crystal display device panel used in the liquid crystal display module is made of plate glass. Avoid any strong mechanical shock. Should the glass break handle it with care.
 - 1.2 The polarizer adhering to the surface of the LCD is made of a soft material. Guard against scratching it.
- 2 Care of the liquid crystal display module against static electricity discharge.
 - 2.1 When working with the module, be sure to ground your body and any electrical equipment you may be using. We strongly recommend the use of anti static mats (made of rubber), to protect work tables against the hazards of electrical shock.
 - 2.2 Avoid the use of work clothing made of synthetic fibers. We recommend cotton clothing or other conductivity-treated fibers.
 - 2.3 Slowly and carefully remove the protective film from the LCD module, since this operation can generate static electricity.
- 3 When the LCD module alone must be stored for long periods of time:
 - 3.1 Protect the modules from high temperature and humidity.
 - 3.2 Keep the modules out of direct sunlight or direct exposure to ultra-violet rays.
 - 3.3 Protect the modules from excessive external forces.
- 4 Use the module with a power supply that is equipped with an over current protector circuit, since the module is not provided with this protective feature.
- 5 Do not ingest the LCD fluid itself should it leak out of a damaged LCD module. Should hands or clothing come in contact with LCD fluid, wash immediately with soap.
- 6 Conductivity is not guaranteed for models that use metal holders where solder connections between the metal holder and the PCB are not used. Please contact us to discuss appropriate ways to assure conductivity.

8. Warranty:

ACROWISE 樺叡電子股份有限公司
 台北縣汐止市大同路三段 192 號 9 樓之一, TEL:(02)8647-2888, FAX(02)8647-2999

Messrs.					
Product Specification	Model:	AWG-S32240AMBHSGWH-F	Rev. No.	Issued Date.	Page.
			A	2008/10/06	21 / 21

This product has been manufactured to your company's specifications as a part for use in your company's general electronic products. It is guaranteed to perform according to delivery specifications. For any other use apart from general electronic equipment, we cannot take responsibility if the product is used in medical devices, nuclear power control equipment, aerospace equipment, fire and security systems, or any other applications in which there is a direct risk to human life and where extremely high levels of reliability are required. If the product is to be used in any of the above applications, we will need to enter into a separate product liability agreement.

- 1 We cannot accept responsibility for any defect, which may arise from additional manufacturing of the product (including disassembly and reassembly), after product delivery.
- 2 We cannot accept responsibility for any defect, which may arise after the application of strong external force to the product.
- 3 We cannot accept responsibility for any defect, which may arise due to the application of static electricity after the product has passed your company's acceptance inspection procedures.
- 4 We cannot accept responsibility for industrial property, which may arise through the use of your product, with exception to those issues relating directly to the structure or method of manufacturing of our product. Acrowise-origin longer than one year from Acrowise production.

9. Dimensional Outlines

- Please see the next page.....

